

POWER[®] *seal* S 70T

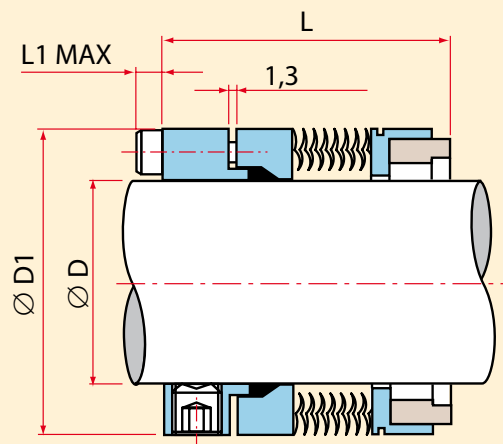

Rozsah použití

Teplota: -75 °C ~ +426 °C

Tlak:

jednovrstvý vlnovec: 20 bar

dvouvrstvý vlnovec: 45 bar

Materiálové složení

Kovové části: SS 316 L / Hastelloy C / Inconel - 718

Rotační plochy: CA / SC / SiC / TC

O-kroužky: grafit

D	D1	L	L1
25.400	39.67	42.8	3.2
28.575	42.85	39.7	3.2
28.575	46.02	42.8	3.2
31.750	49.20	44.5	3.2
38.100	55.11	44.5	4.2
41.275	58.29	44.5	4.2
44.450	61.47	44.5	4.2
47.625	64.64	44.5	4.2
50.800	67.82	44.5	4.2
53.975	70.99	44.5	4.2
57.150	74.17	47.6	4.2
60.325	77.34	47.6	4.2
63.500	80.95	47.6	4.2
66.675	84.12	47.6	4.2
69.850	87.30	47.6	4.2
73.025	92.08	47.6	4.8
76.200	95.25	47.6	4.8
79.375	98.43	47.6	4.8
82.550	98.43	47.6	4.8
85.725	104.78	47.6	4.8
88.900	107.95	47.6	4.8
92.075	111.13	47.6	4.8
92.250	114.30	47.6	4.8
98.425	117.48	47.6	4.8
101.60	120.65	47.6	4.8
104.77	130.18	50.8	6.3
107.95	130.18	50.8	6.3
111.12	136.53	50.8	6.3
114.30	136.53	50.8	6.3
117.47	142.87	50.8	6.3
120.65	142.87	50.8	6.3